



TMR2922

Ultra High Sensitivity TMR linear sensor

General Description

The TMR2922 linear sensor utilizes a unique push-pull Wheatstone bridge composed of four unshielded TMR sensor elements. The unique bridge design provides a high sensitivity differential output that is linearly proportional to a magnetic field applied parallel to the surface of the sensor package, and it provides superior temperature compensation of the output. The TMR2922 is available a 6mm X 5mm X 1.5mm SOP8 package.

Features and Benefits

- Tunneling Magneto resistance (TMR) Technology
- High Sensitivity (7~15mV/V/Oe)
- Large Dynamic Range
- Very Low Power Consumption
- Excellent Thermal Stability
- Very Low Hysteresis
- Compatible with wide Range of Supply Voltages
- Ultra Low Noise Spectral Density(<1nT/sqrt(Hz)@1Hz)



TMR2922

Applications

- Weak Magnetic Field Sensing
- Current Sensors
- Position and Displacement Sensing

Transfer Curve

The following figure shows the response of the TMR2922 to an applied magnetic field in the range of ±15 Oe when the TMR2922 is biased at 1V.

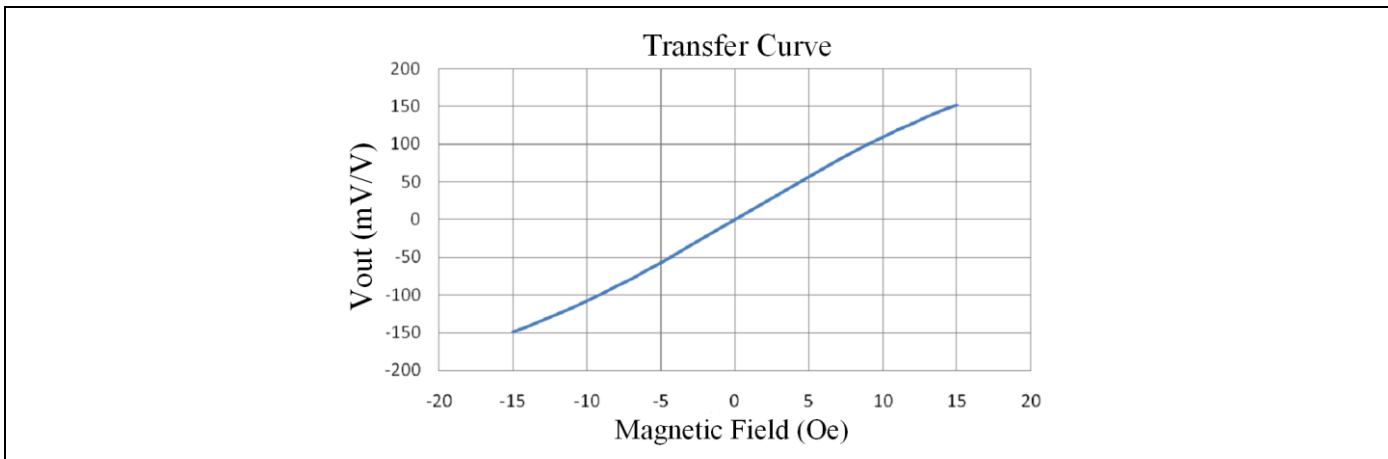

Pin Configuration

(Arrow indicates direction of applied field that generates a positive output voltage.)

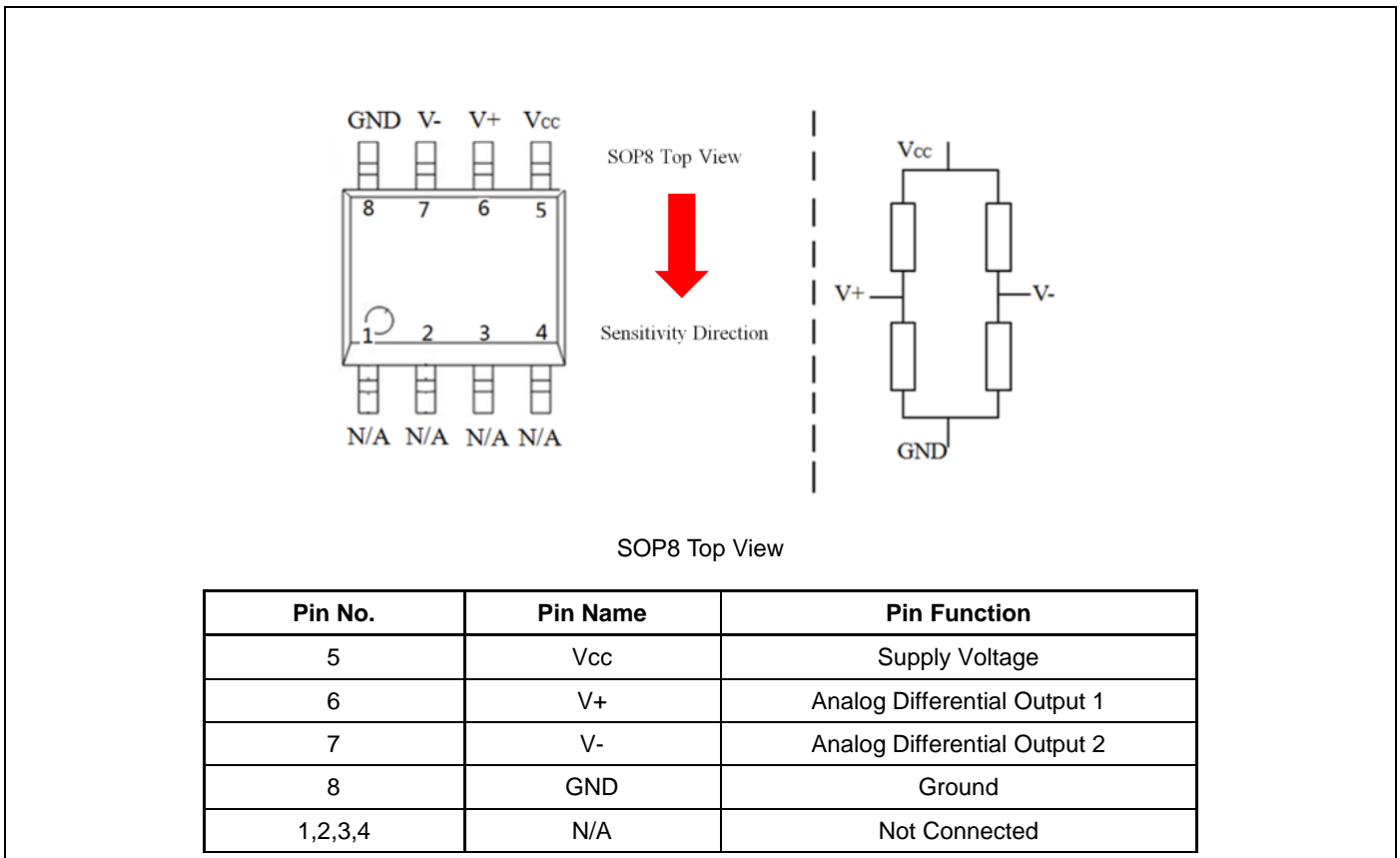

Absolute Maximum Ratings

Parameter	Symbol	Limit	Unit
Supply Voltage	V _{CC}	7	V
Reverse Supply Voltage	V _{RCC}	7	V
Max Exposed Field	H _E	4000	Oe ⁽¹⁾
ESD Voltage	V _{ESD}	4000	V
Operating Temperature	T _A	-40~125	°C
Storage Temperature	T _{stg}	-50 ~150	°C

Specification (V_{CC}=1.0V, T_A=25°C, Differential Output)

Parameter	Symbol	Conditions	Min	Typ	Max	Unit
Supply Voltage	V _{CC}	Operating		1	7	V
Supply Current	I _{CC}	Output Open		0.5		mA
Resistance	R			2 ⁽²⁾		KOhm
Sensitivity	SEN	Fit @ ±15 Oe	7		18	mV/V/Oe
Saturation Field	H _{sat}			±30		Oe
Non-Linearity	NONL	Fit @ ±15 Oe		2		%FS
Offset Voltage	V _{offset}		-20		20	mV/V
Hysteresis	Hys	Fit @ ±15 Oe			3	Oe

Temperature Coefficient of Resistance	TCR	H = 0 Oe		-500		PPM/°C
Temperature Coefficient of Sensitivity	TCS			-1100		PPM/°C

Notes:

- (1) 1 Oe (Oersted) = 1 Gauss in air = 0.1 millitesla = 79.8 A/m.
- (2) Custom resistance may be available upon request.

Package Information

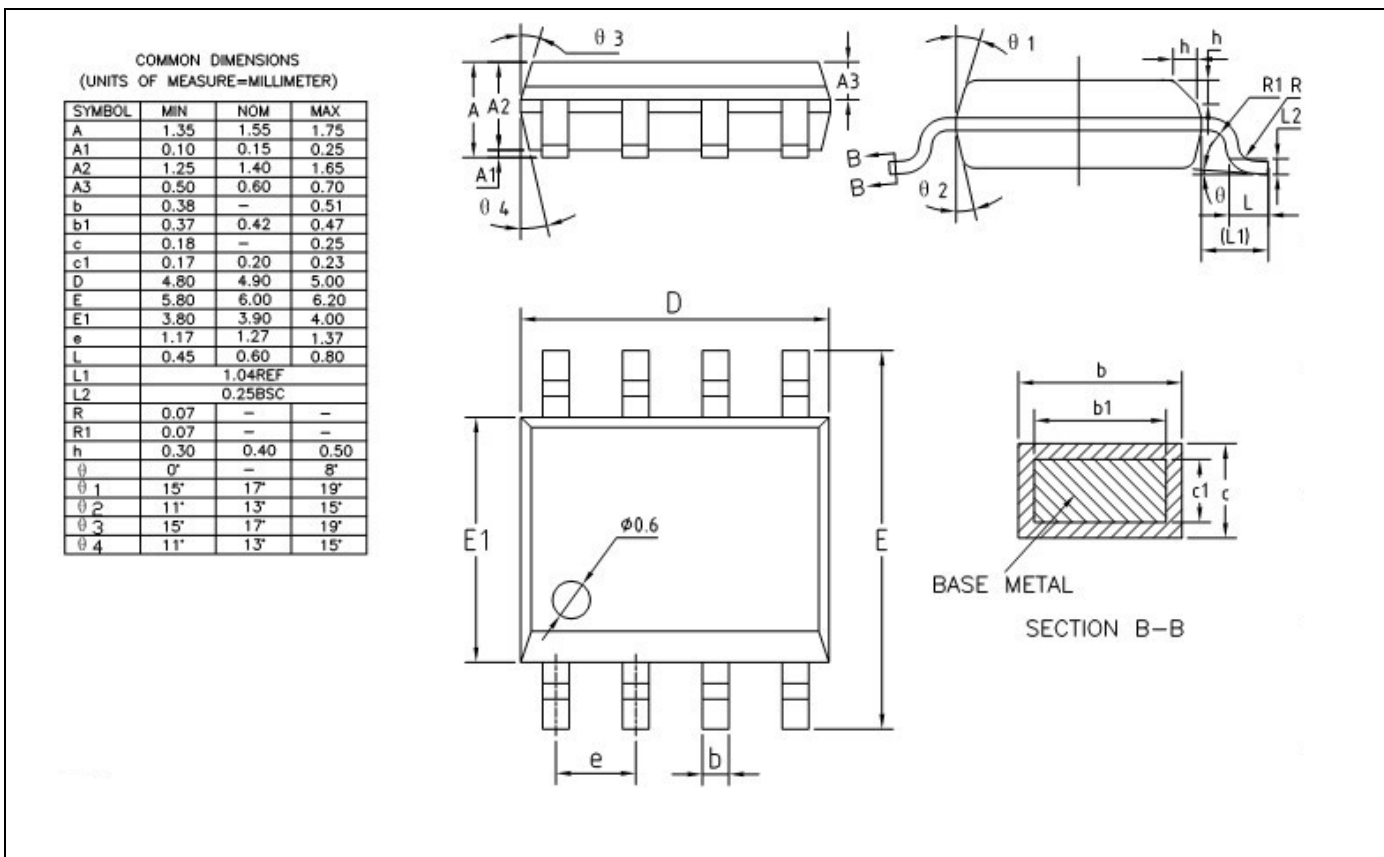

TMR Sensor Position

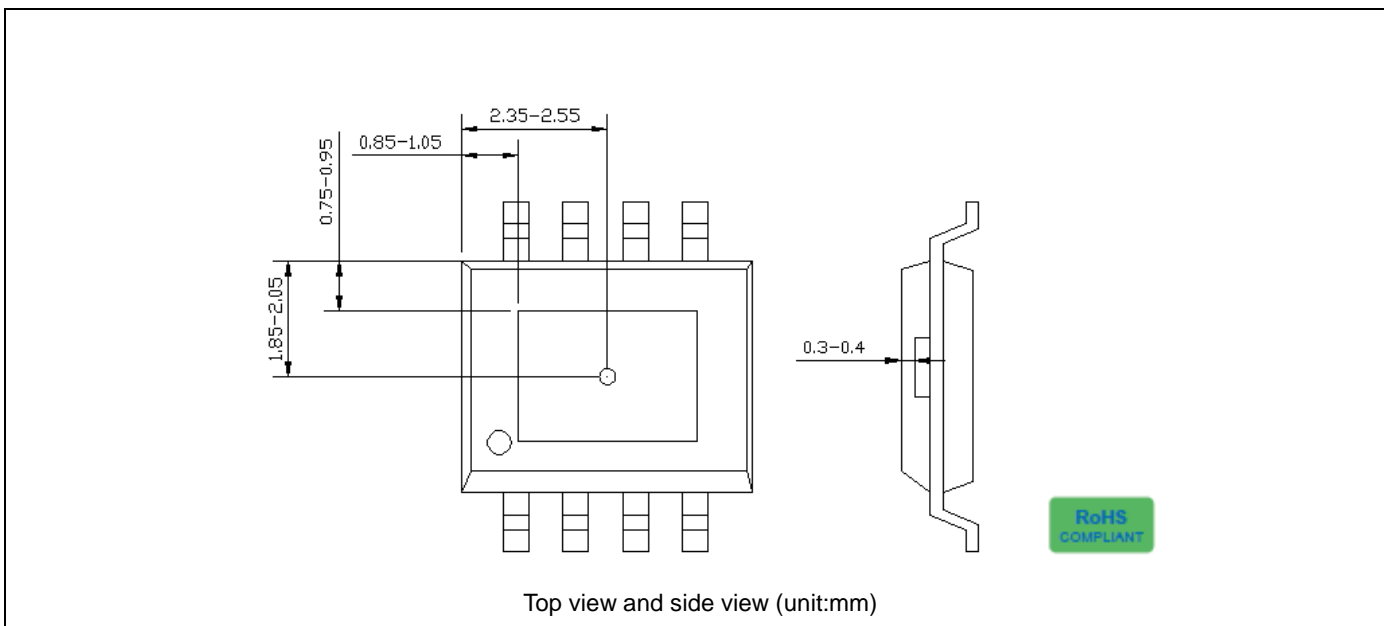



American Electronic Components Inc.

1101 Lafayette Street, Elkhart, Indiana 46516, United States of America.

Web: www.aecensors.com Email: sales@aecensors.com

Toll: 888 847 6552, Tel: +1 574 293 8013

The information provided herein by MultiDimension Technology Co., Ltd. (hereinafter MultiDimension) is believed to be accurate and reliable. Publication neither conveys nor implies any license under patent or other industrial or intellectual property rights. MultiDimension reserves the right to make changes to product specifications for the purpose of improving product quality, reliability, and functionality. MultiDimension does not assume any liability arising out of the application and use of its products. MultiDimension's customers using or selling this product for use in appliances, devices, or systems where malfunction can reasonably be expected to result in personal injury do so at their own risk and agree to fully indemnify MultiDimension for any damages resulting from such applications.